



TREND O
INNOVATIVE FX BROKER

BRAND GUIDELINE

Our Brand, Our Pride

Trendo is a leading global broker, committed to delivering innovative and seamless trading experiences. With a focus on transparency, security, and cutting-edge technology, we empower traders to thrive in the financial markets with confidence.

LOGO VARIATION & HOW TO USE IT

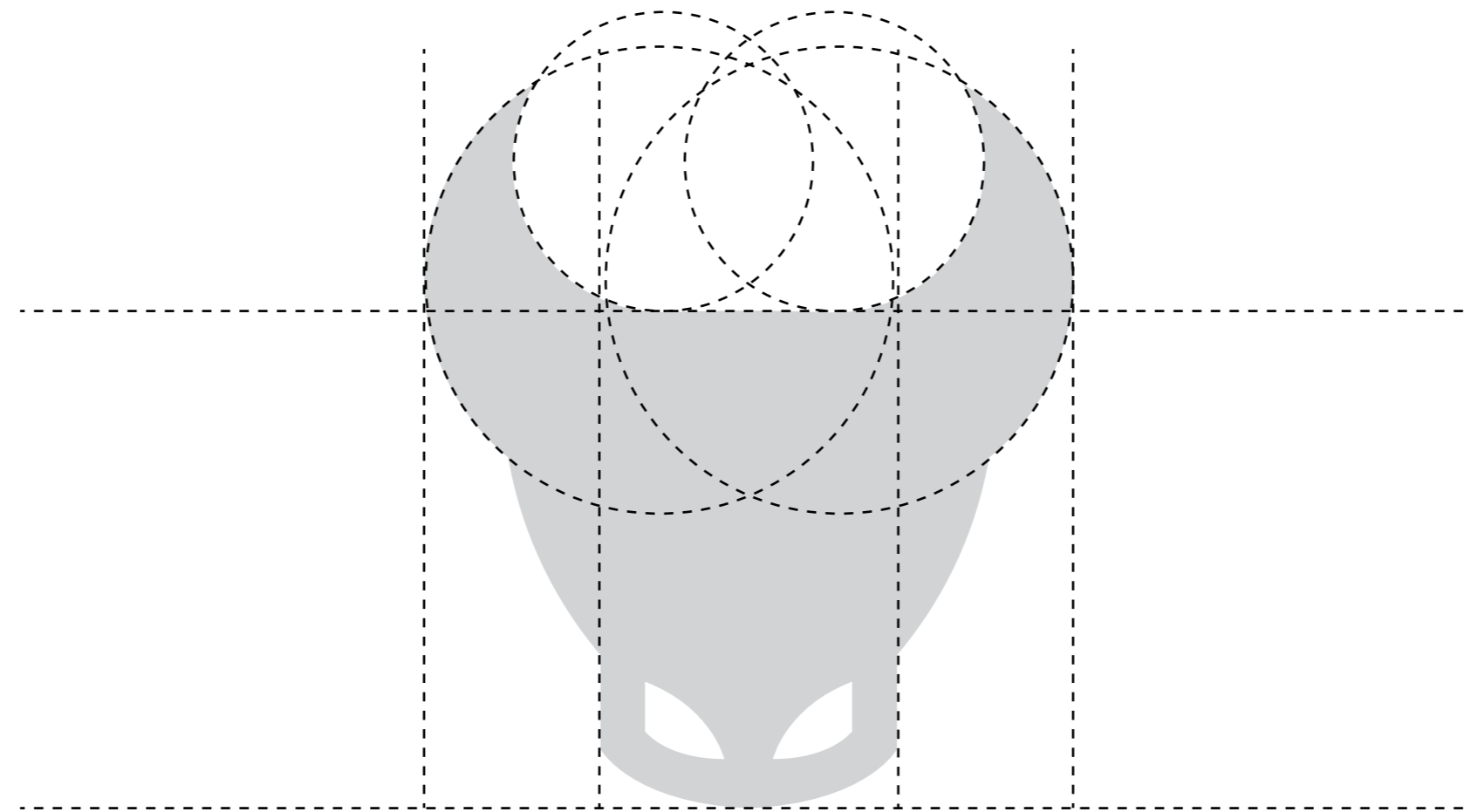

TREND O

Vertical



TREND O
INNOVATIVE FX BROKER

Horizontal



TREND O
INNOVATIVE FX BROKER

OUR HISTORY & PROFILE



The Trendo Story

The Trendo brand name was born from traders' common phrase, "following the trend." Our design team fused this concept into a fresh, five-letter coinage: TRENDO. With its angled terminals and dynamic flow, the name evokes the movement of Japanese candlesticks on a chart, symbolizing the inevitability of market trends. This name, combined with our commitment to innovation, perfectly reflects Trendo's mission to empower traders with confidence and cutting-edge tools.

Upward-curving horns and a confident gaze embody the universal symbol of bullish market sentiment. The Trendo logo emerged from a vision to capture the moment every trader dreams of: the rise of a bullish chart. A bold bull's head symbolizing strength and optimism was paired with the name TRENDO, reflecting market movement and momentum.

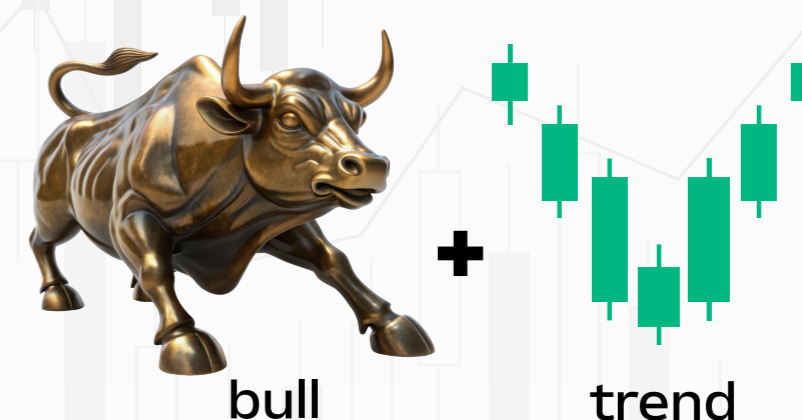

COLOR PALLETE

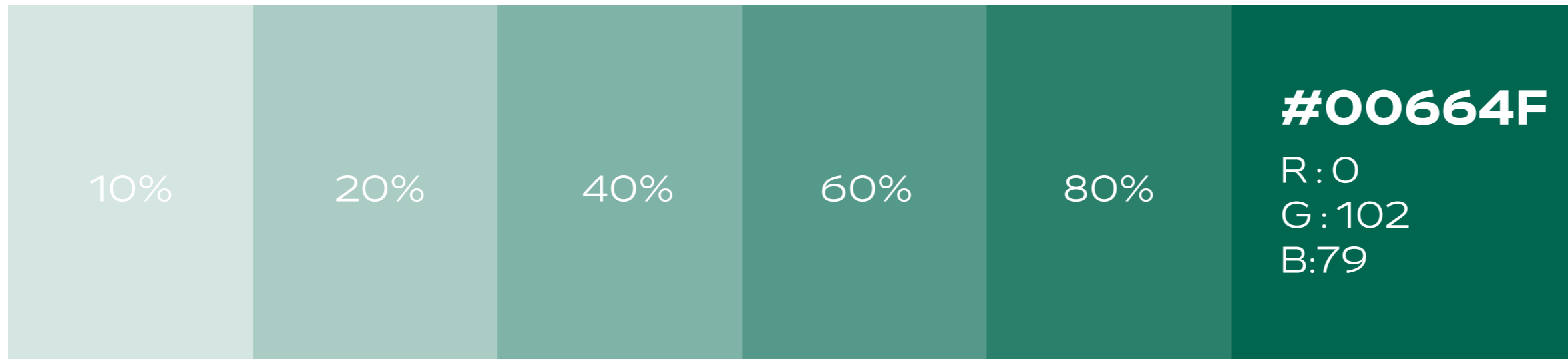
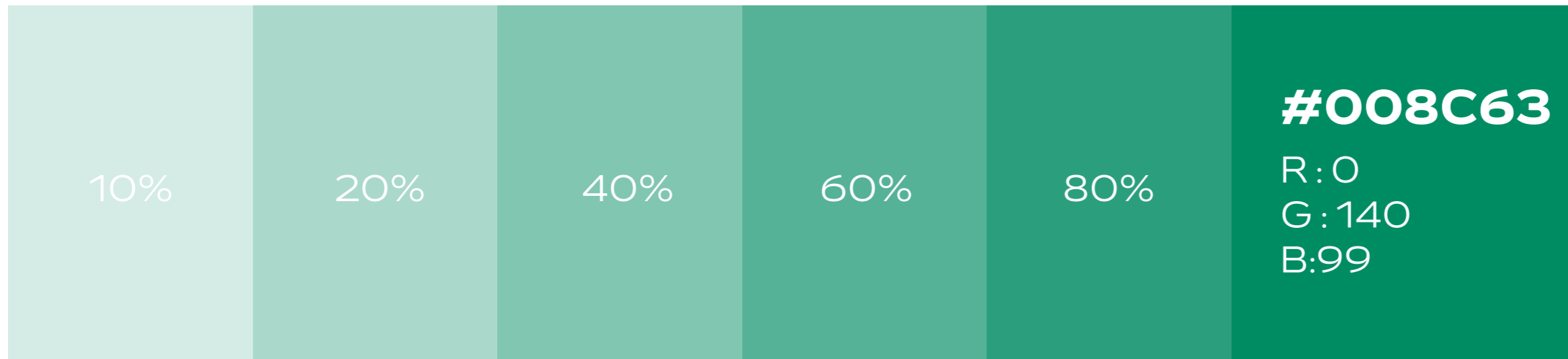
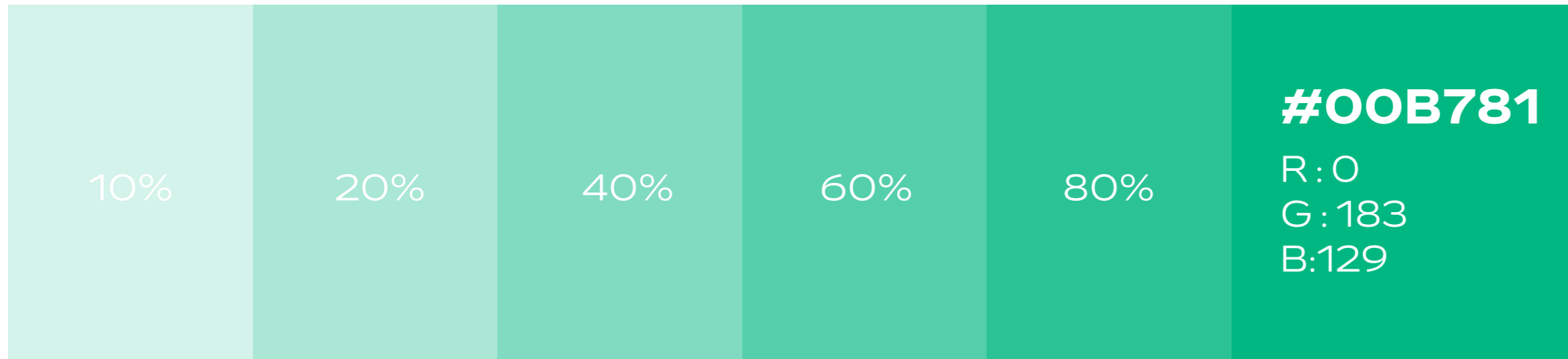

TYPOGROPHY

For brand english texts please use
YekanBakh (PRO+) family fonts

Aa

A B C D E F G H I J K L M N O P R S T U V W X Y Z
a b c d e f g h i j k l m n o p r s t u v w x y z
1 2 3 4 5 6 7 8 9 10

Aa

A B C D E F G H I J K L M N O P R S T U V W X Y Z
a b c d e f g h i j k l m n o p r s t u v w x y z
1 2 3 4 5 6 7 8 9 10

Aa

A B C D E F G H I J K L M N O P R S T U V W X Y Z
a b c d e f g h i j k l m n o p r s t u v w x y z
1 2 3 4 5 6 7 8 9 10

Aa

A B C D E F G H I J K L M N O P R S T U V W X Y Z
a b c d e f g h i j k l m n o p r s t u v w x y z
1 2 3 4 5 6 7 8 9 10

Aa

A B C D E F G H I J K L M N O P R S T U V W X Y Z
a b c d e f g h i j k l m n o p r s t u v w x y z
1 2 3 4 5 6 7 8 9 10

Aa

A B C D E F G H I J K L M N O P R S T U V W X Y Z
a b c d e f g h i j k l m n o p r s t u v w x y z
1 2 3 4 5 6 7 8 9 10

For brand persian texts please use
YekanBakh (PRO+) family fonts

Thin — ترندو، بهترین انتخاب برای معامله‌گران حرفه‌ای

Light — ترندو، بهترین انتخاب برای معامله‌گران حرفه‌ای

Regular — ترندو، بهترین انتخاب برای معامله‌گران حرفه‌ای

SemiBold — ترندو، بهترین انتخاب برای معامله‌گران حرفه‌ای

Bold — ترندو، بهترین انتخاب برای معامله‌گران حرفه‌ای

ExtraBold — ترندو، بهترین انتخاب برای معامله‌گران حرفه‌ای

Black — ترندو، بهترین انتخاب برای معامله‌گران حرفه‌ای

ExtraBlack — ترندو، بهترین انتخاب برای معامله‌گران حرفه‌ای

PRINT & STATIONERY



BRAND ASSETS

Click [HERE](#) to download the following brand toolkit assets:

- Trendo Logo.png
- Trendo Logo.svg
- Trendo Logo.eps
- Trendo Logo.ai
- Trendo Brandbook.pdf
- Trendo Screenshots.png
- Fonts

By using the Trendo brands in these guidelines (the “Guidelines”), you agree to the Guidelines as well as our Terms of Service and all other rules and policies.

These Guidelines apply to your use of the Trendo brand. You may use the Trendo brand assets solely for the purposes expressly authorized by Trendo. Strict compliance with these Guidelines is required at all times, and any use of the Trendo brand in violation of these Guidelines will automatically terminate any permission related to your use of the brand, its assets, and services

THANK YOU